



CATALOG SF100

ESSMUELLER

SCREW FEEDERS

Model "SF"
4" thru 24"

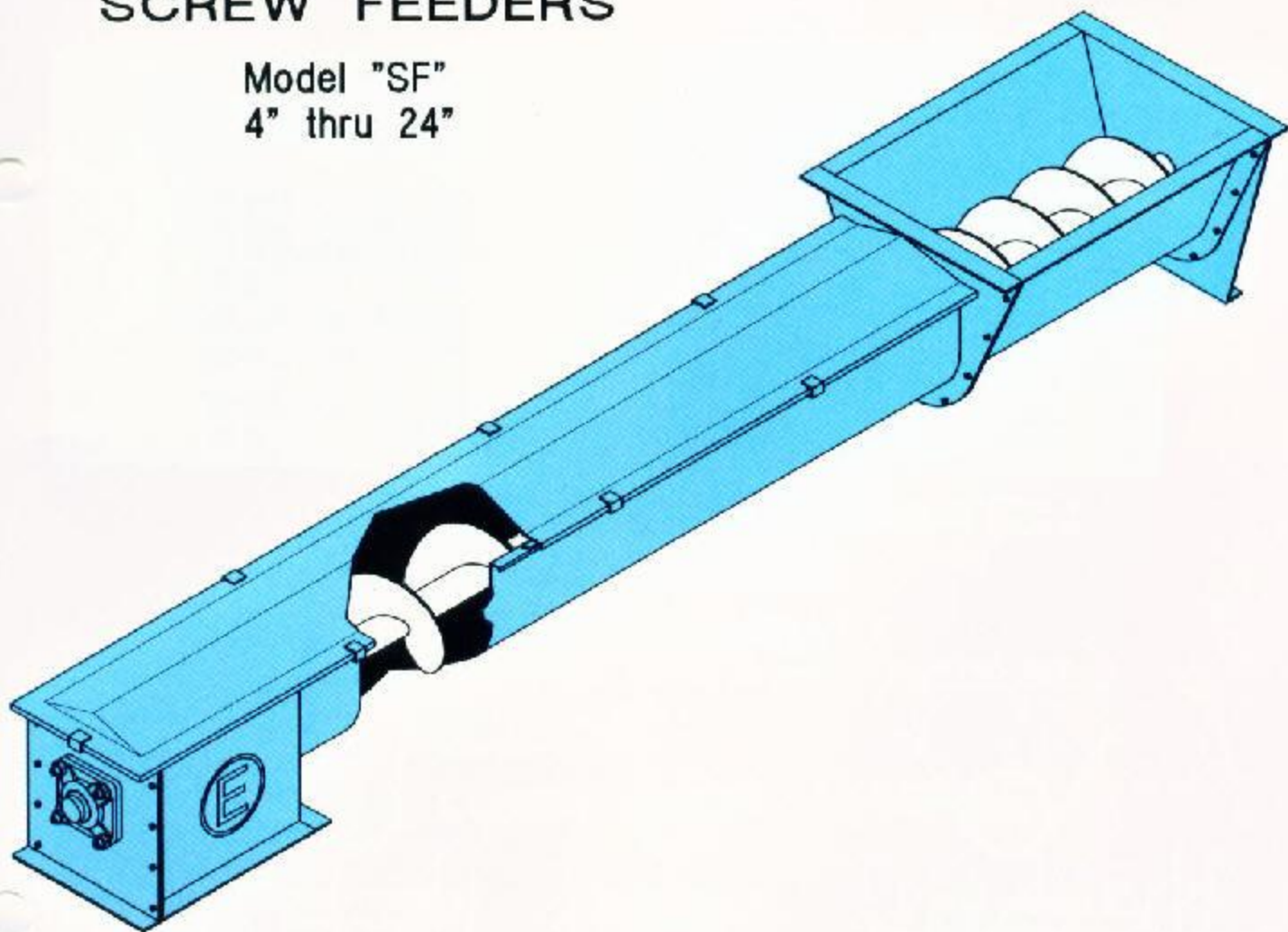

another premium product of
The ESSMUELLER Company

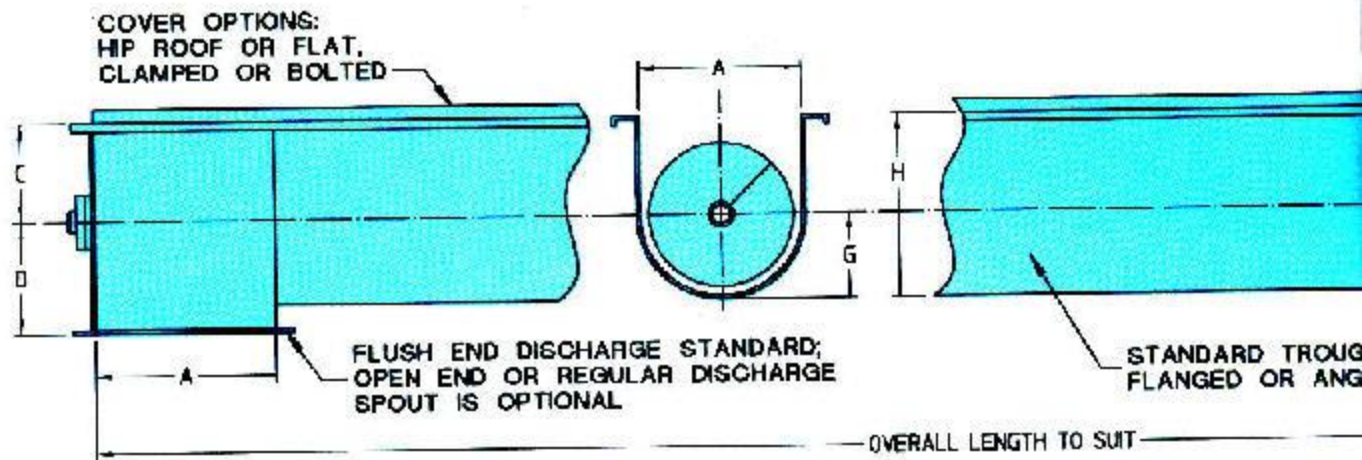

MODEL SF

SIZE	A	B*	C	D	E
4	5	30	3 5/8	3 3/4	6
6	7	36	4 1/2	5	7
9	10	42	6 1/8	7 1/8	9
12	13	48	7 3/4	8 7/8	10
14	15	54	9 1/4	10 1/8	11
16	17	56	10 5/8	11 1/8	11 1/2
18	19	58	12 1/8	12 3/8	12 1/8
20	21	60	13 1/2	13 3/8	13 1/2
24	25	64	18 1/2	15 3/8	18 1/2

* MAXIMUM IN STANDARD CONSTRUCTION. LONGER INLETS
REQUIRE ENGINEERING CONSIDERATION.

STANDARD INLETS

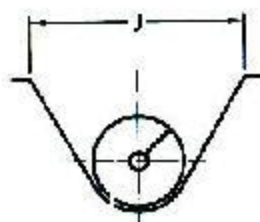

FLARED INLET
DOUBLE
(BOTH SIDES)

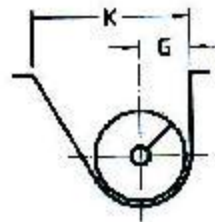

FLARED INLET
SINGLE
(ONE SIDE ONLY)
(EITHER SIDE)

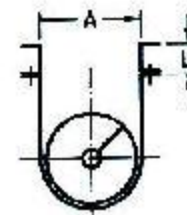

DIRECT INLET
NON-FLARED
INLET MAY BE OMITTED AND
TROUGH BOLTED DIRECTLY TO
HOPPER DISCHARGE FLANGE

FEEDER DIMENSIONS

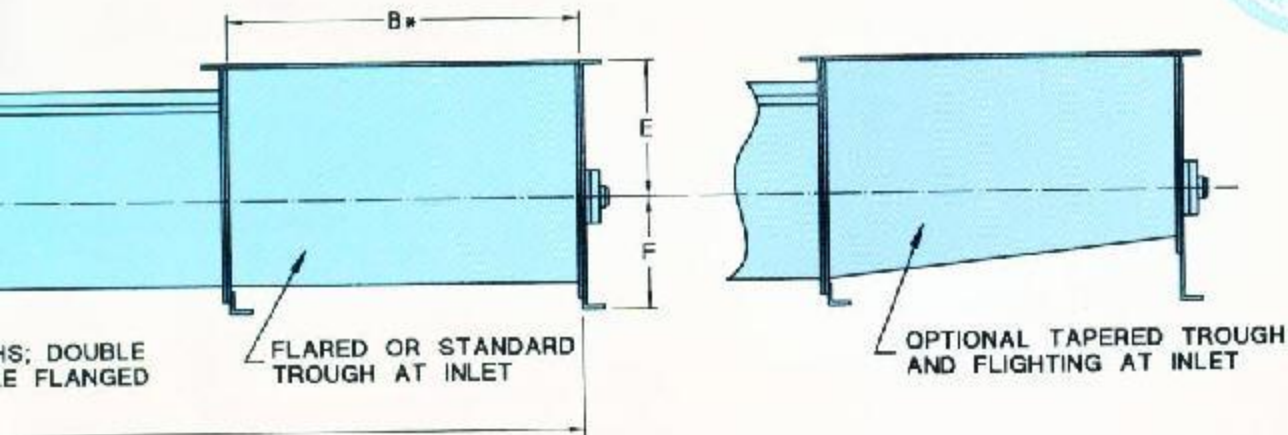

F	G	H	J	K	L
4 5/8	2 1/2	6 1/8	10	7 1/2	3
5 5/8	3 1/2	8	14	10 1/2	3
7 7/8	5	11 1/8	18	14	3
9 5/8	6 1/2	14 1/4	22	17 1/2	3
10 7/8	7 1/2	16 3/4	24	19 1/2	3
12	8 1/2	19 1/8	28	22 1/2	3
13 3/8	9 1/2	21 5/8	31	25	3
15	10 1/2	24	34	27 1/2	3
18 1/8	12 1/2	29	40	32 1/2	3

STANDARD FEATURES

- CEMA STANDARDIZED COMPONENTS SELECTED BASED ON PRODUCT CHARACTERISTICS
- SHROUDS WITH INLETS
- BARE PIPE AT DISCHARGE
- SHOP MOUNTED DISCHARGE SPOUT
- FLIGHTS FULLY WELDED TO PIPE ON CARRYING SIDE
- SHAFT SEALS
- SHOP ASSEMBLED
- ESSMUELLER QUALITY

SCREW FEEDER TYPES



SINGLE

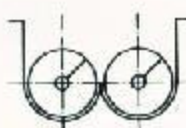

DOUBLE

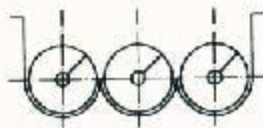

TRIPLE

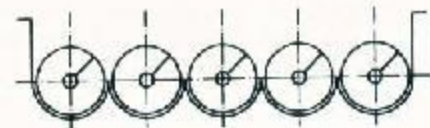

LIVE BOTTOM FEEDER

CAPACITIES OF SINGLE SCREW FEEDERS

SIZE	MAXIMUM RPM	CFH @ 1 RPM	CFH @ MAX. RPM
4	75	1.46	110
6	70	4.98	349
9	65	18.5	1203
12	60	44.4	2664
14	55	70	3850
16	50	104.7	5235
18	45	151	6795
20	40	209	8360
24	30	363	10890

CONSULT ESSMUELLER FOR YOUR SPECIFIC APPLICATION

THESE CAPACITIES ARE BASED ON 100% OF THEORETICAL CAPACITY WITH STANDARD PITCH AND SCREW PIPE WITH CHOKE LOADED FREE FLOWING MATERIALS

CAPACITIES, SPEEDS AND HORSEPOWERS REQUIRED WILL VARY BY MATERIAL, MOISTURE CONTENT, NON-STANDARD PITCH OR PIPE SIZE

NOTE: CONSTRUCTION FEATURES AND SPECIFICATIONS ARE SUBJECT TO CHANGE WITH PRODUCT HANDLED AND/OR WITHOUT NOTICE

POPULAR OPTIONS

HEAVY DUTY FLIGHTING - HEAVY DUTY COMPONENTS
SHORT PITCH FLIGHTING - DOUBLE FLIGHTING
VARIABLE PITCH FLIGHTING - TAPERED FLIGHTING
STAINLESS STEEL - GALVANIZING - SPECIAL MATERIALS
FLOW INDICATION SWITCHES - PLUG SWITCHES
ABRASION RESISTANT LINERS - TUBULAR TROUGH
SPECIAL SHAFT SEALS - FEEDER EXTENSIONS
FLARED INLET EXTENSIONS - OPEN END DISCHARGES
ELECTRIC MOTOR AND DRIVE PACKAGES

OTHER QUALITY ESSMUELLER EQUIPMENT

ROUND BOTTOM DRAG CONVEYORS
FLAT BOTTOM DRAG CONVEYORS
L-PATH VERTICAL DRAG CONVEYORS
BUCKET ELEVATORS
TURNHEAD DISTRIBUTORS



THE ESSMUELLER COMPANY

P.O. BOX 1966, LAUREL, MISSISSIPPI 39441-1966

PHONE: TOLL-FREE 1-800-325-7175 - FAX: 1-601-649-4320